

MATLAB® and Simulink®: Accelerate 5G and LTE/WLAN Research and Development

John Wang, Ph.D.
Industry Manager
Communications, Electronics and Semiconductors
MathWorks

Towards 5G: LTE and WLAN will Continue to Play a Key Role

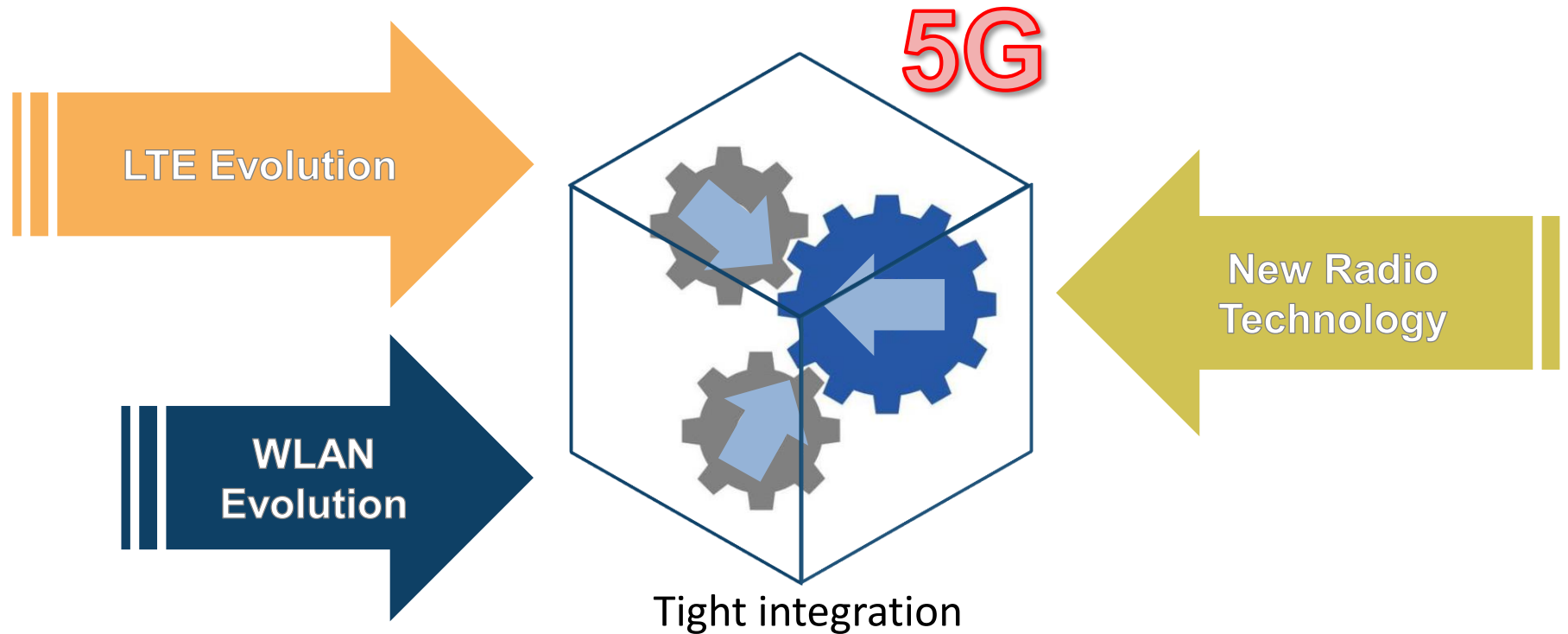

A 5G vision

Use cases

- Ultra mobile wideband
- Enhanced capacity
- Massive device connectivity
- Robust IoT

Requirements

- Ultra broadband
- Ultra narrowband
- Reduced latency
- Massive device connectivity
- Energy saving
- Cost reduction
- Tight interworking with LTE

Solutions

- Existing & new bands (below and above 6GHz)
- Carrier aggregation
- New waveforms (OFDM based?)
- Massive MIMO
- Flexible duplex
- Shorter TTIs
- Advanced receivers
- Flexible cells (micro, pico, femto)

Agenda

- **4G**
 - **LTE System Toolbox**
 - **WLAN System Toolbox**
 - Working with real signals: SDR
 - Examples:
 - LTE 8x8 link modelling
 - WLAN beamforming
 - Interference suppression in LTE with **Phased Array System Toolbox**
- **5G**
 - FBMC, UFMC modelling
 - LTE and UFMC modelling

LTE and WLAN with MATLAB

What is the LTE System Toolbox?

- Standard-compliant **physical layer** models in MATLAB:
Releases 8, 9, 10, 11 and 12
- Scope:
 - FDD / TDD
 - Uplink / Downlink
 - Transmitter / Receiver
 - Conformance tests & link level simulation
- ~200 functions for physical layer modelling

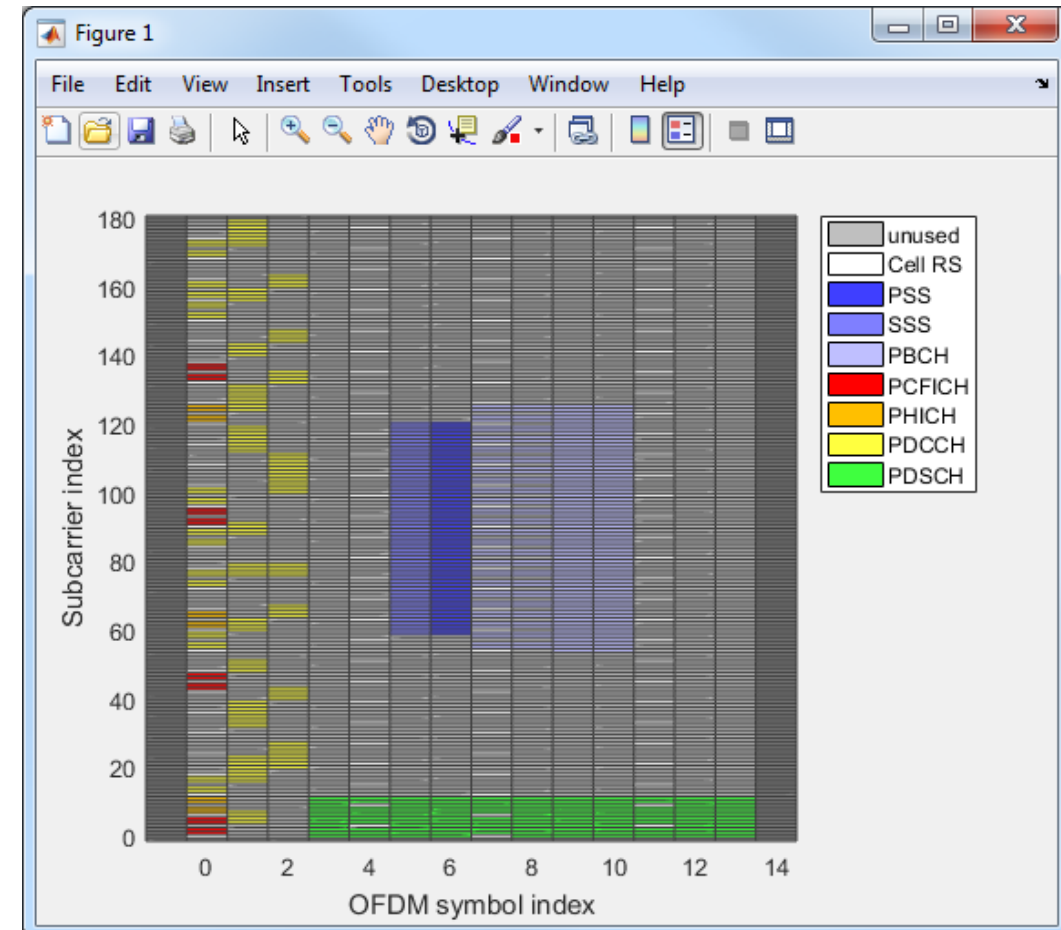

LTE System Toolbox: Capabilities

- Physical Signals
 - Physical Channels
 - Transport Channels
 - Control Information
 - OFDM/SC-FDMA Modulation/Demodulation
 - Reception and recovery:
 - Synchronisation
 - Channel Estimation
 - Equalisation
 - Cell search procedure
 - Channel Models
 - Functions for Test and Measurement
- Coding/decoding

Comprehensive



Quick Example: Easy LTE Signal Generation

Command Window

```
>> enb = lteRMCDL('R.0');
>> [wave, grid]=lteRMCDLTool(enb, [1 0 0]);
fx >> |
```

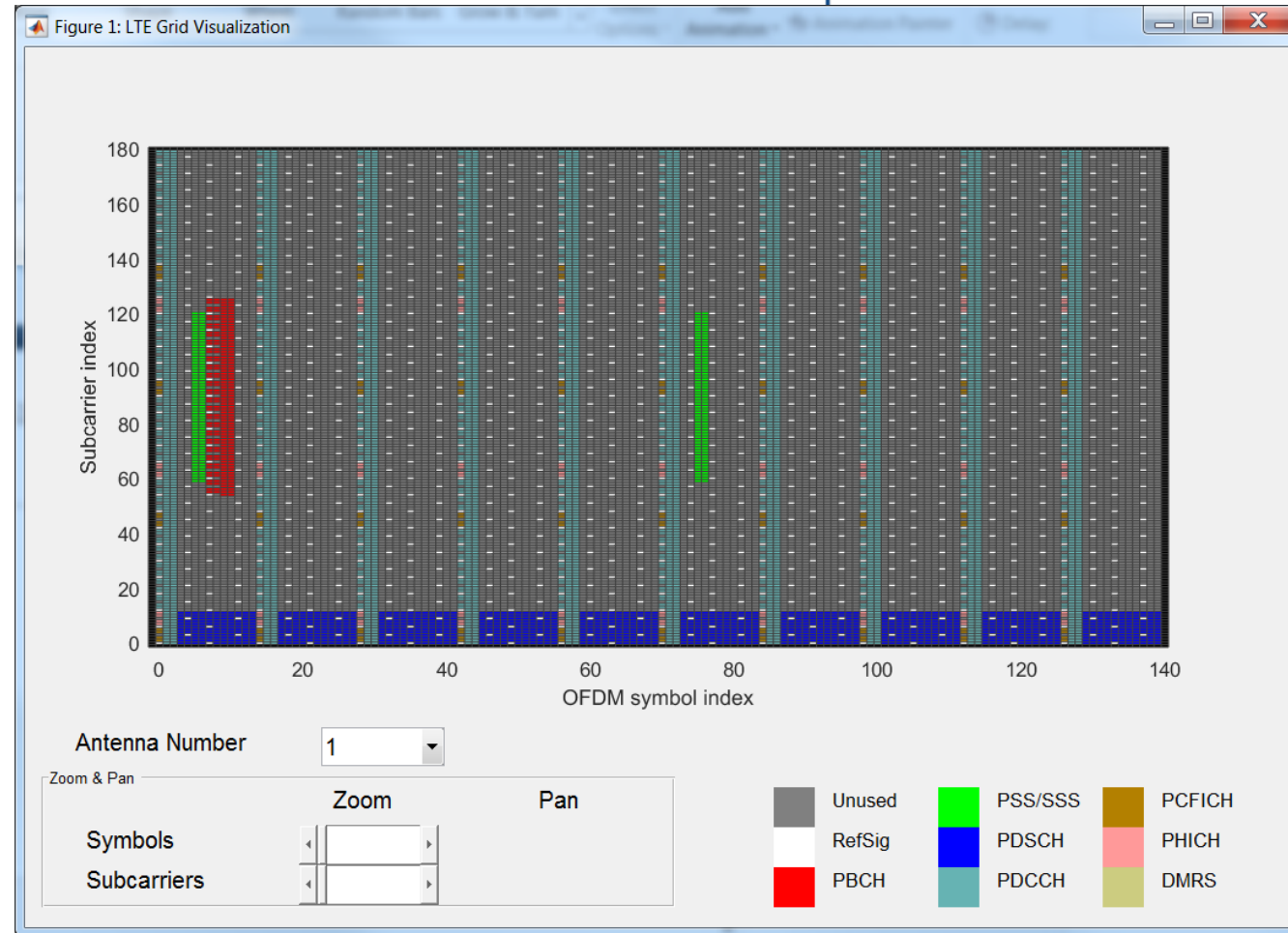

Toolbox Granularity: Low and Mid Level

PDSCH Example

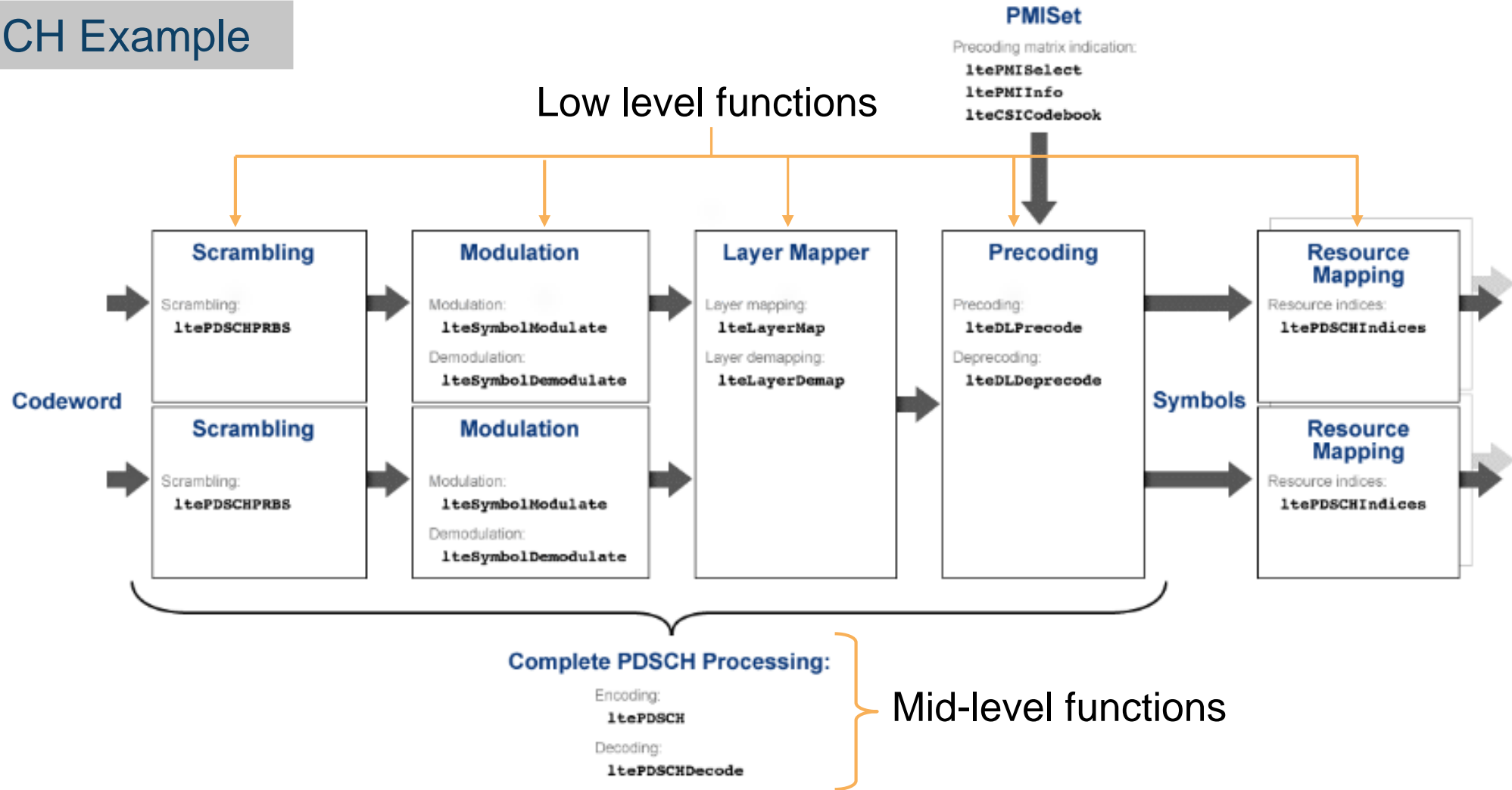

Toolbox Granularity: High Level (Signal Generators)

```

% Establish the number of component carriers.
numCC = length(NDLRB);

% Create transmission for each component carrier
enb = cell(1,numCC);
for i = 1:numCC
    enb{i} = lteRMCDL('R.5');
    enb{i}.NDLRB = NDLRB(i);

```

MATLAB function

GUI Based

Example: Full Transmit and Receive Chain

- Release 12 carrier aggregation

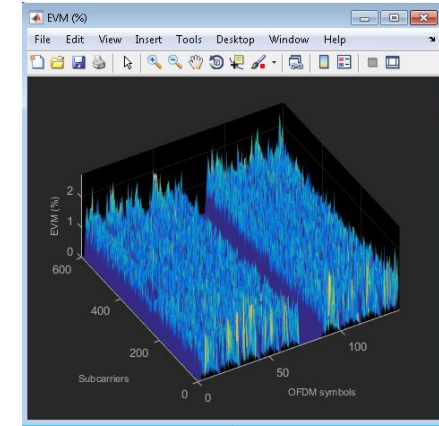
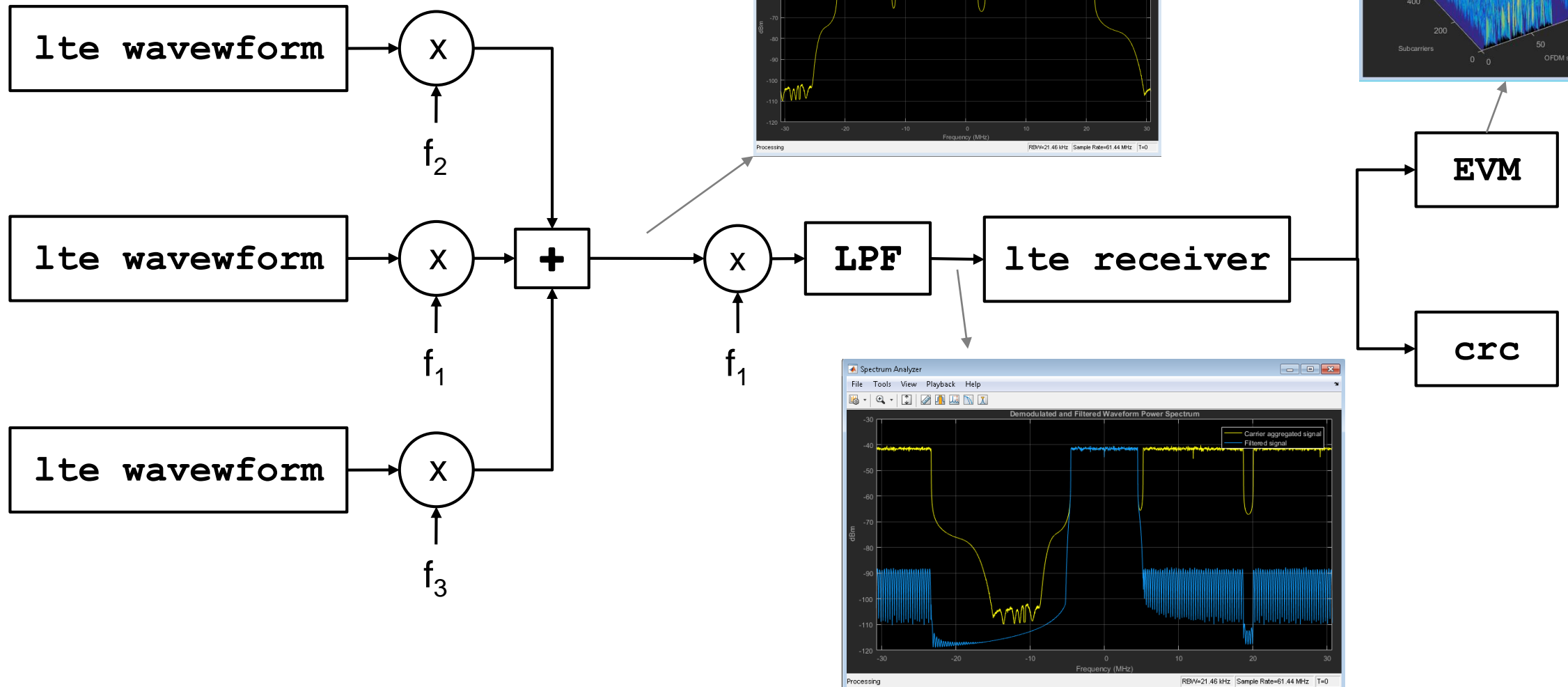

WLAN System Toolbox

- Standard compliant **physical layer** models:
 - 802.11ac
 - 802.11n
 - 802.11p
 - 802.11a/b/g/j

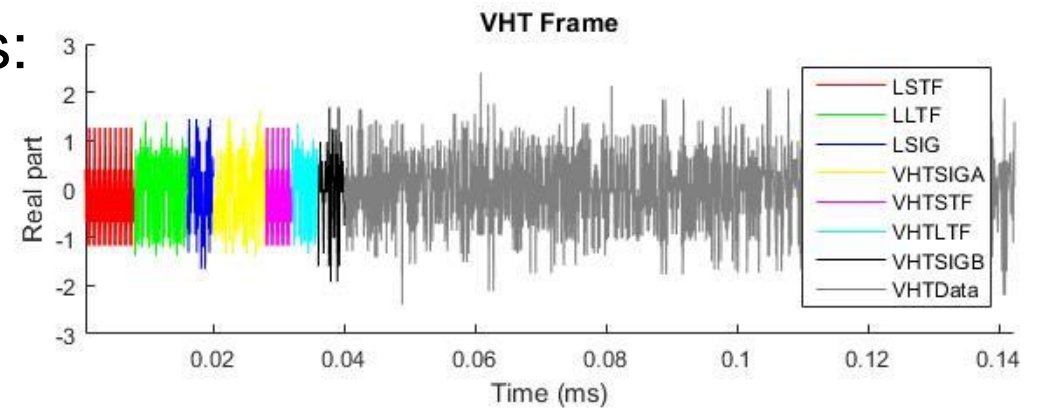

- Transmit and receive capabilities
- Open customizable MATLAB code
- C-code generation enabled with MATLAB Coder

```

% OFDM demodulation
[ofdmDemodData, ofdmDemodPilots] = wlanOFDMDemodulate( ...
    rxVHTData(1:minInputLen, :), cfgOFDM, symOffset);

% Pilot phase tracking
if calculateCPE==true || strcmp(pilotPhaseTracking, 'PreEQ')
    % Get reference pilots, from Eqn 22-95, IEEE Std 802.11ac-2013
    % Offset by 4 to allow for L-SIG, VHT-SIG-A, VHT-SIG-B pilot symbols
    z = 4;
    refPilots = vhtPilots(numOFDMSym, z, chanBW, numSTS);
  
```

MATLAB Coder
Generate C and C++ code

Supported WLAN Standards

Standard	Bandwidth (MHz)	MIMO	Designation
802.11ac	20, 40, 80, 160	Up to 8 spatial streams, MU-MIMO	VHT Very High Throughput
802.11n	20 40	Up to 4 spatial streams	HT High Throughput
802.11g	20	N/A	Non-HT
802.11a	20	N/A	
802.11b	20	N/A	

WLAN Toolbox uses the VHT, HT, Non-HT naming convention

Quick Example : Generate WLAN Signal

Command Window

```
>> cfgVHT = wlanVHTConfig;  
>> VHTsignal = wlanWaveformGenerator([1 0 0 1],cfgVHT,'NumPackets',3,'IdleTime',5e-6);  
fx >>
```

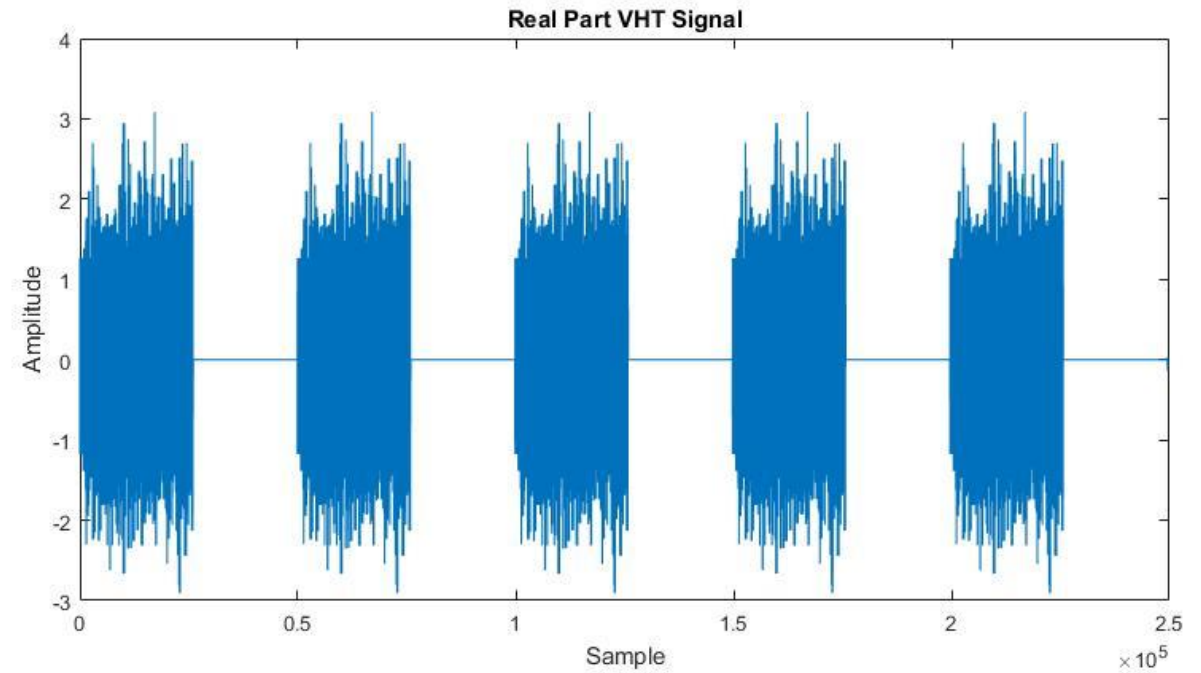
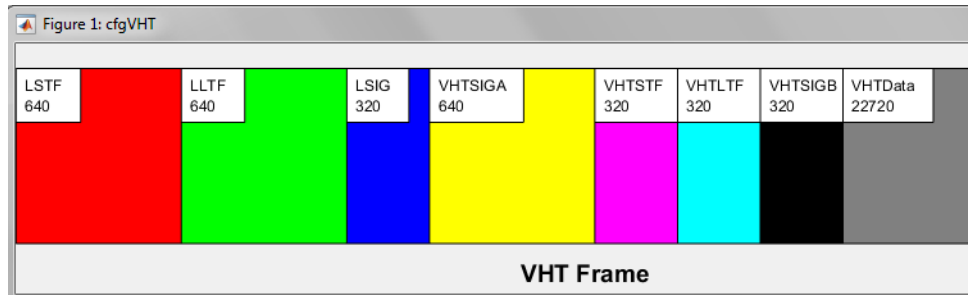

Toolbox Granularity

- Generate fields individually

```
Command Window  
>> lstf = wlanLSTF(cfgVHT);  
>> lltf = wlanLLTF(cfgVHT);  
>> lsig = wlanLSIG(cfgVHT);  
fx >> |
```

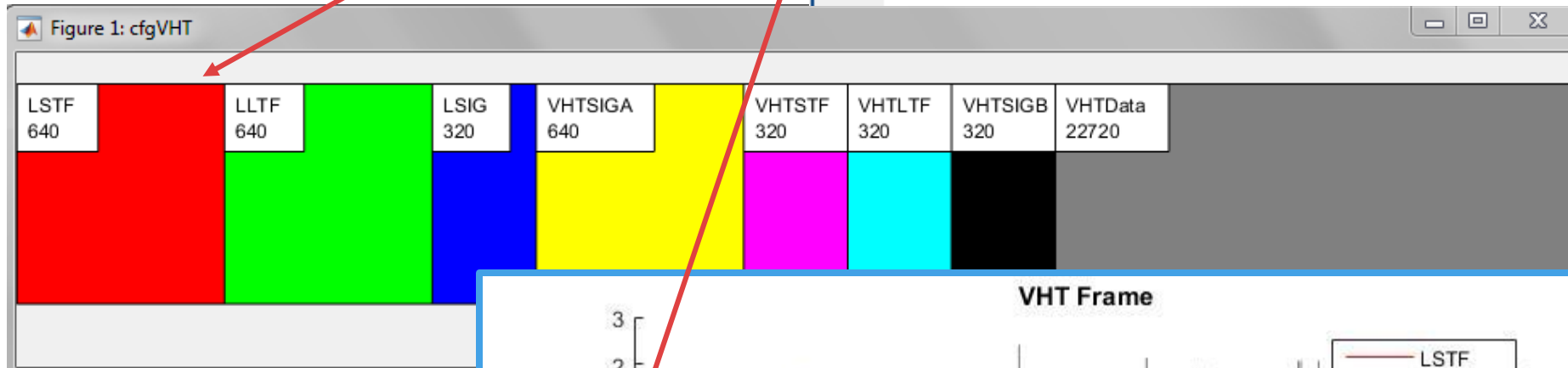

Short Training Field

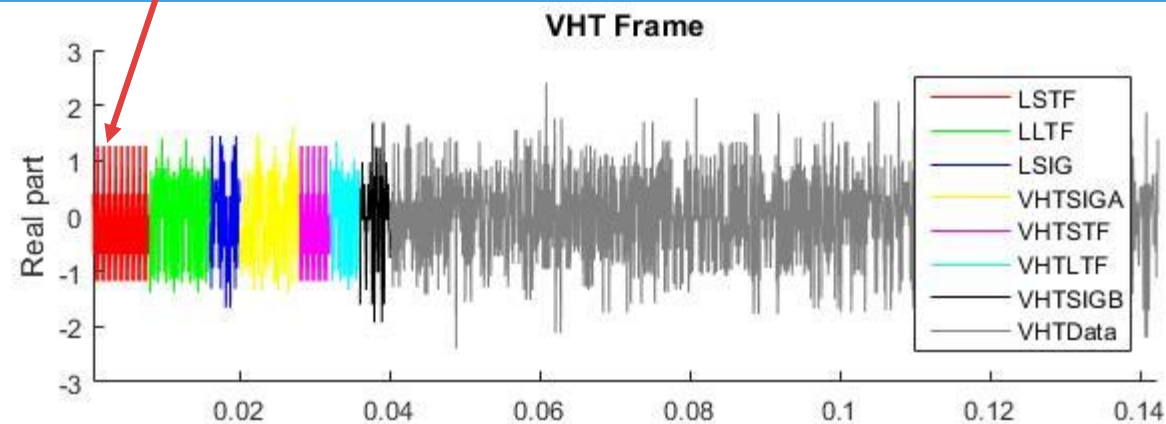

Typical Use Cases for LTE & WLAN System Toolboxes



Golden Reference for Verification

Does my design work as it should?

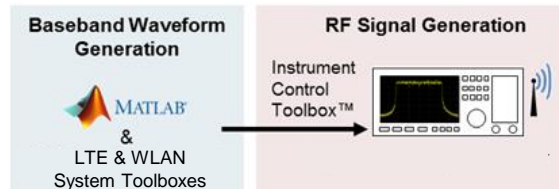

Signal Generation/Analysis

Test with live data

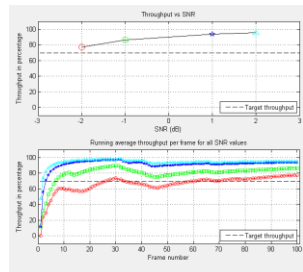

Throughput?
Quality?

End-To-End Simulation

*How do design choices affect system performance?
Does my system conform to the standard?*

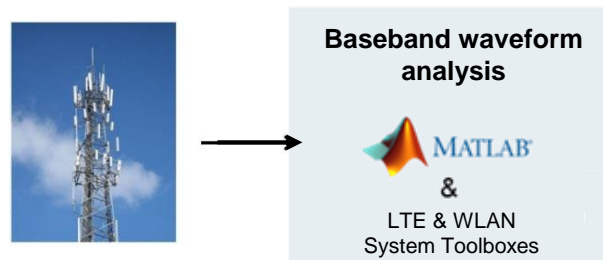

Signal Information Recovery

Decode real-world signals

LTE and WLAN with MATLAB: Working with Real Signals

Hardware & Radio Connectivity

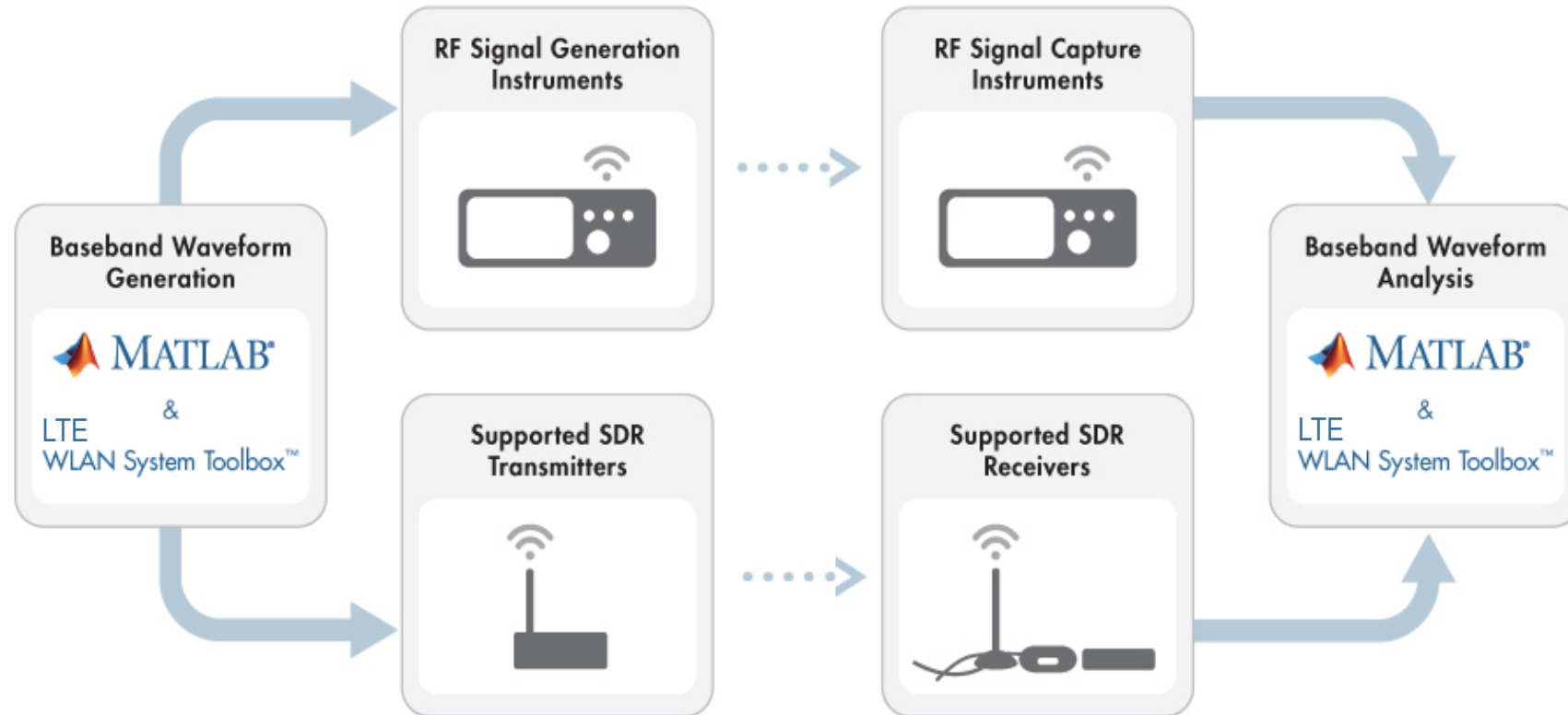

LTE Scanner: System Setup

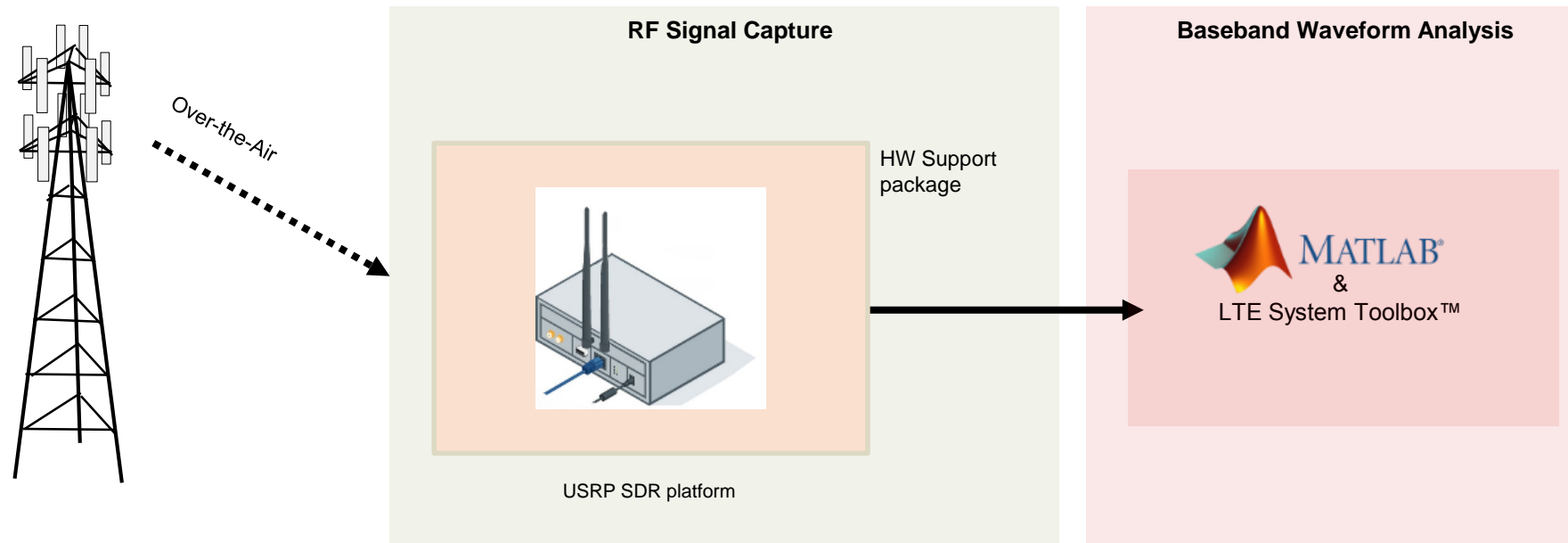

LTE Scanner

Search for LTE Cell settings and information from within a chosen frequency range.

Search settings

Receiver hardware: USRP - B200/B210

LTE band number: 20

LTE band frequency (MHz): 791-821 MHz

User defined frequencies: [805,807;815,817]

Cell information recovery: MIB & SIB1

Reference signal plot type: RSRQ

Plot Spectrum
Start Search
Stop

Reference Signal Measurement vs. Frequency

Status output:

```

Successfully decoded MIB settings at 816 MHz.
NDLRB=50.

Now performing SIB1 recovery...

Reconfiguring radio hardware to sample at 15.36Ms/s
for SIB1 recovery.

Capturing new data frames at 15.36Ms/s
Processing captured frames.
  Skipping frame 663 (odd frame number does not
  contain SIB1).
  Attempting decoding for frame 664.
  Successful SIB1 recovery.

Searching 817 MHz...

Search complete.
          
```

Choose recovered cell information: 816 MHz - Cell ID: 401 319 227

Cell settings from MIB decoding

Frequency: 816 MHz

DuplexMode: FDD

CyclicPrefix: Normal

NDLRB: 50

NCellID: 401 319 227

NSubframe: 0

CellRefP: 2

PHICHDuration: Normal

Ng: One

NFrame: 663

Reference signal measurements

RSRP: 12.5 dBm RSRQ: -24.23 dB

RSSI: 44.46 dBm

PDSCH settings from DCI Decoding

RNTI: 65535

PRBSet: 0 1 2 3 4 5 6 7

NLayers: 2

Modulation: QPSK

RV: 3

TxScheme: TxDiversity

Working with Off the Air WLAN Signals

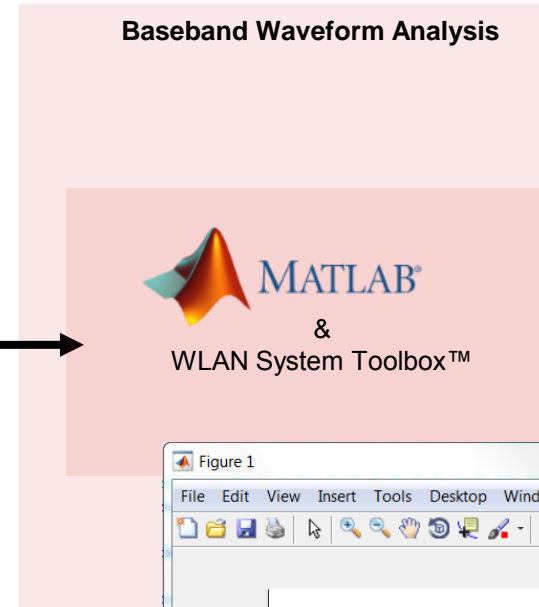
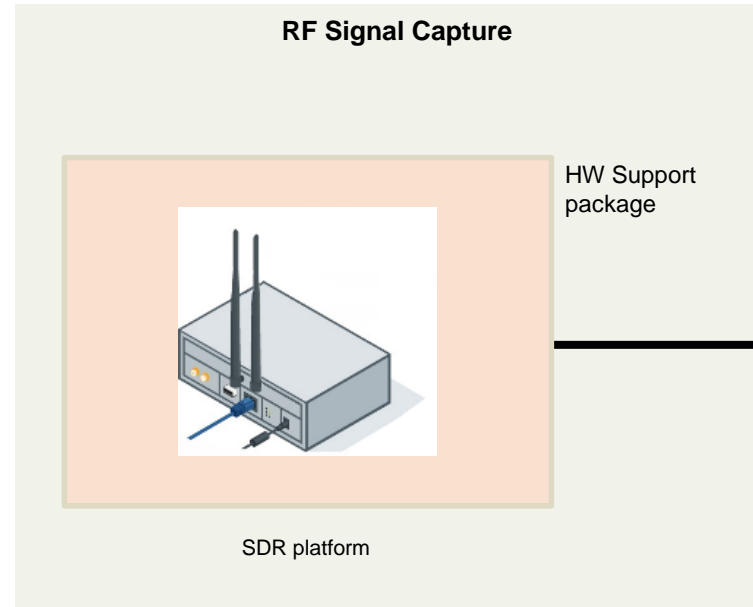
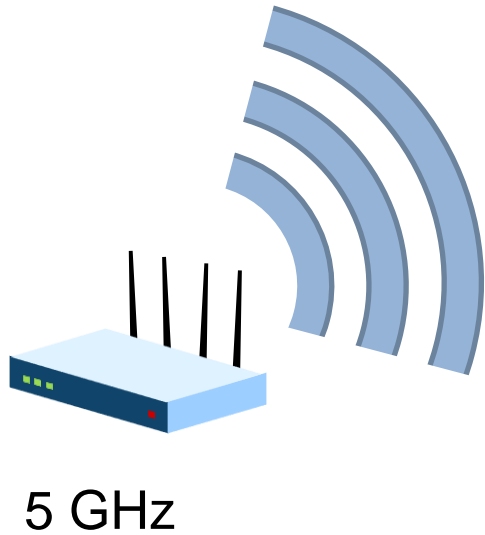

```

Command Window
## Establishing connection to hardware. This process...
-----
Packet-1 detected at index 884546
L-SIG check pass
Decoded L-SIG contents:
          MCS: 0
          Length: 170
          Number of samples in packet: 5040

Beacon Interva: 100 0
Timestamp: 72 208 185 66 41 0 0 0
SSID: ASUS_5G
SN: 255
HT Capable
-----
Packet-2 detected at index 2932594
L-SIG check pass
Decoded L-SIG contents:
          MCS: 0
          Length: 170
          Number of samples in packet: 5040

Beacon Interva: 100 0
Timestamp: 74 96 187 66 41 0 0 0
SSID: ASUS_5G
  
```

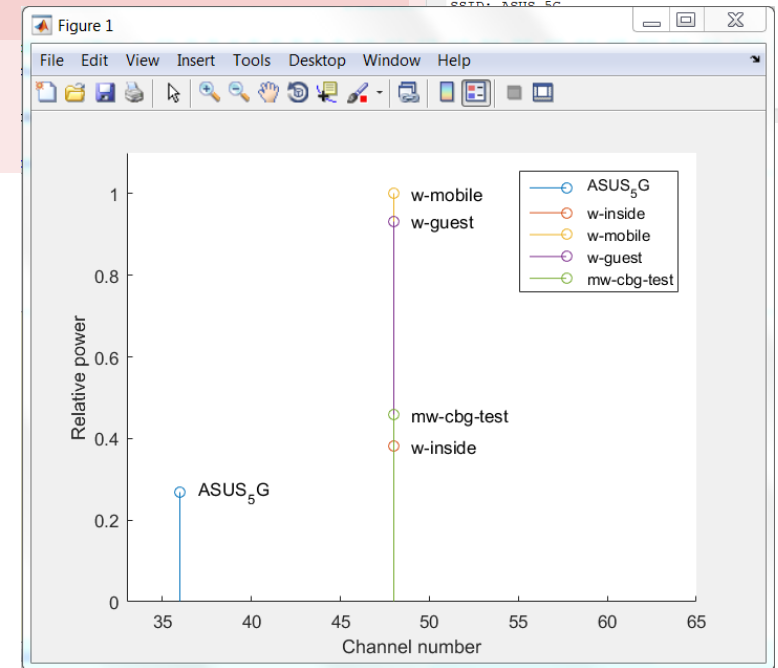

Practical Demos

Example: LTE Multi-antenna Throughput Simulation

- Up to 8x8 antenna scenario
- Fully flexible
- TDD Duplexing
- Supports beamforming or spatial multiplexing
 - Support for transmission modes TM7, TM8, TM9 and TM10

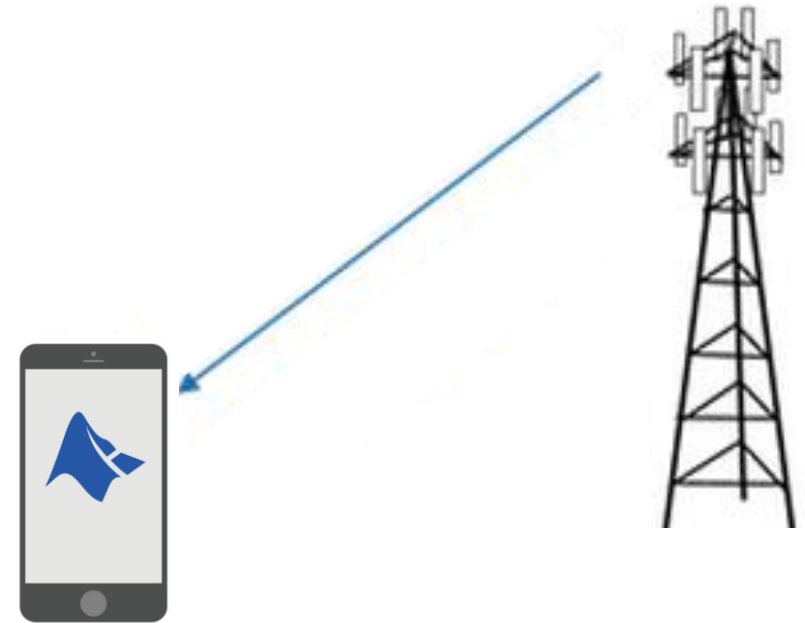

System Setup

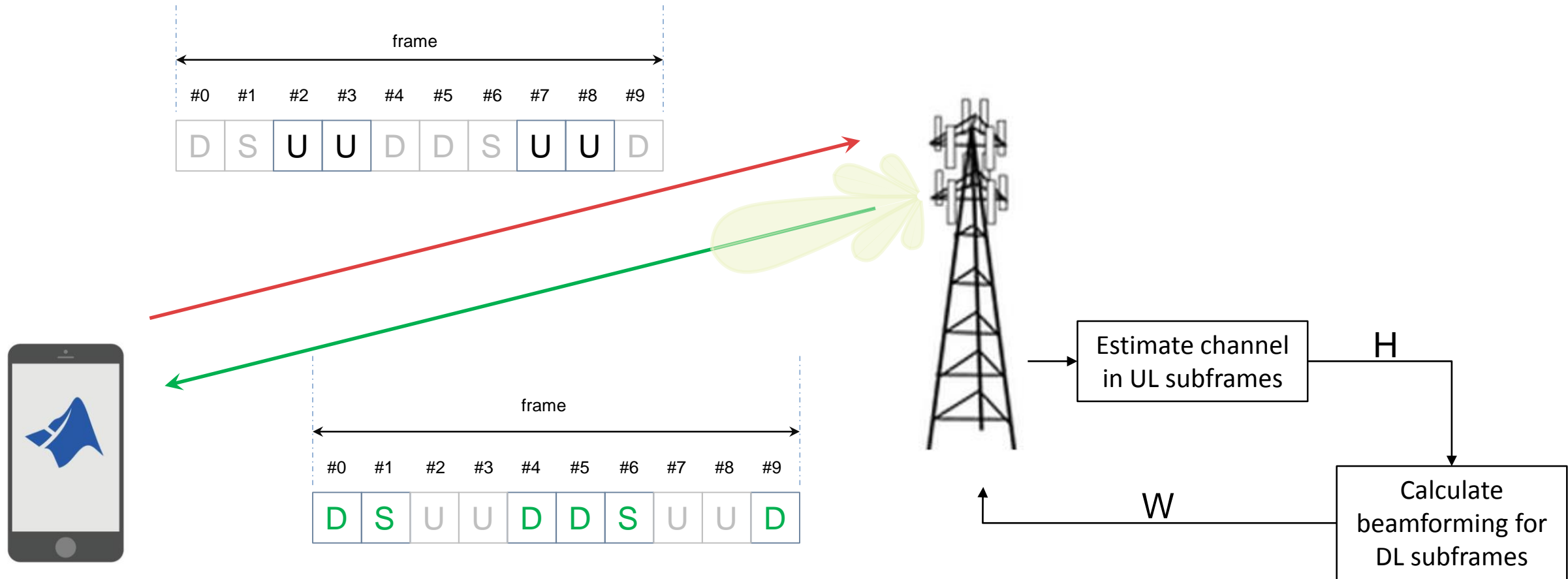

Beam-steering Matrix Calculation

- Use UL subframes for channel estimation
- Use that estimate to calculate beamsteering matrix
- Apply beamsteering in DL subframes

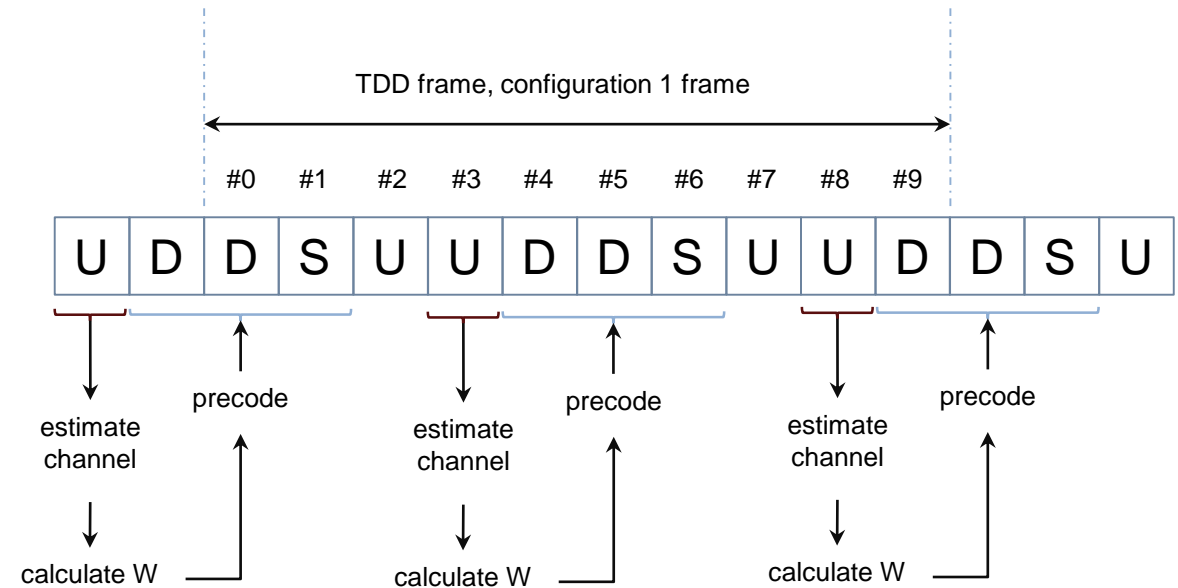
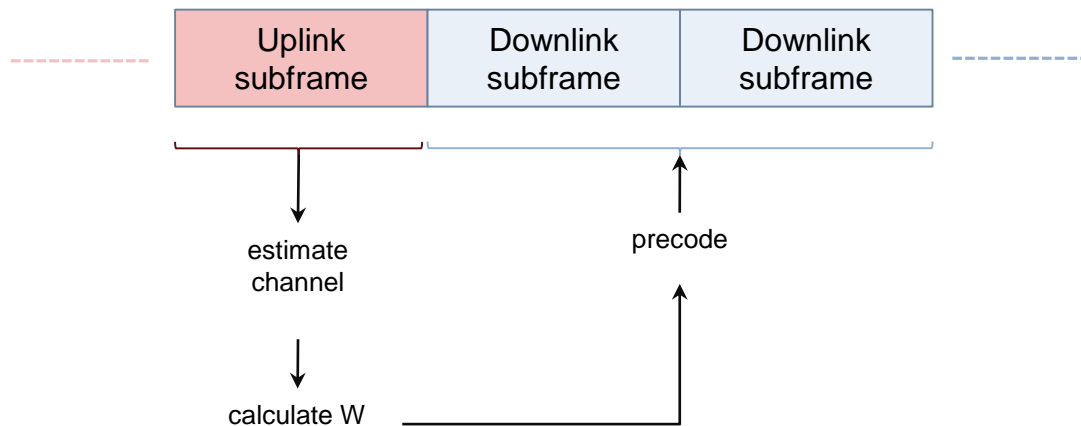

Example: WLAN (802.11ac) Beamforming

- Study the effect of different beamforming techniques in WLAN environment

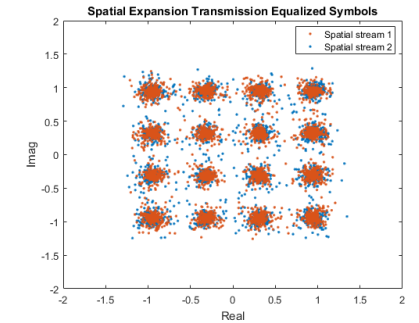
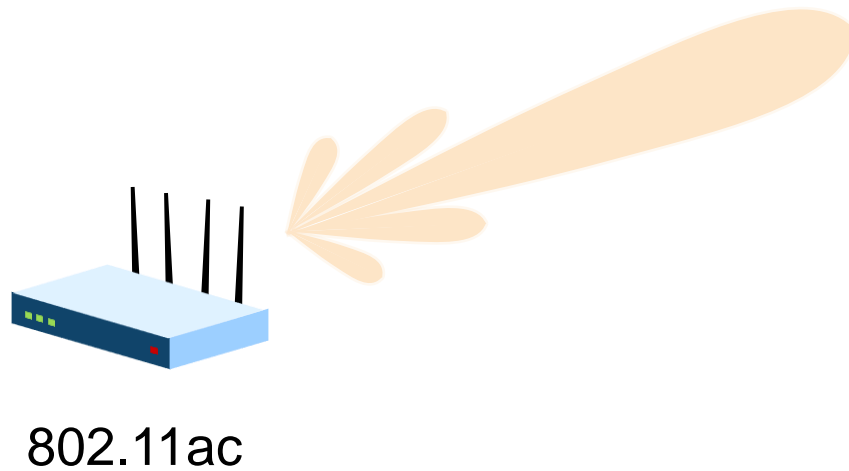

System Model: Spatial Expansion vs. Beamforming

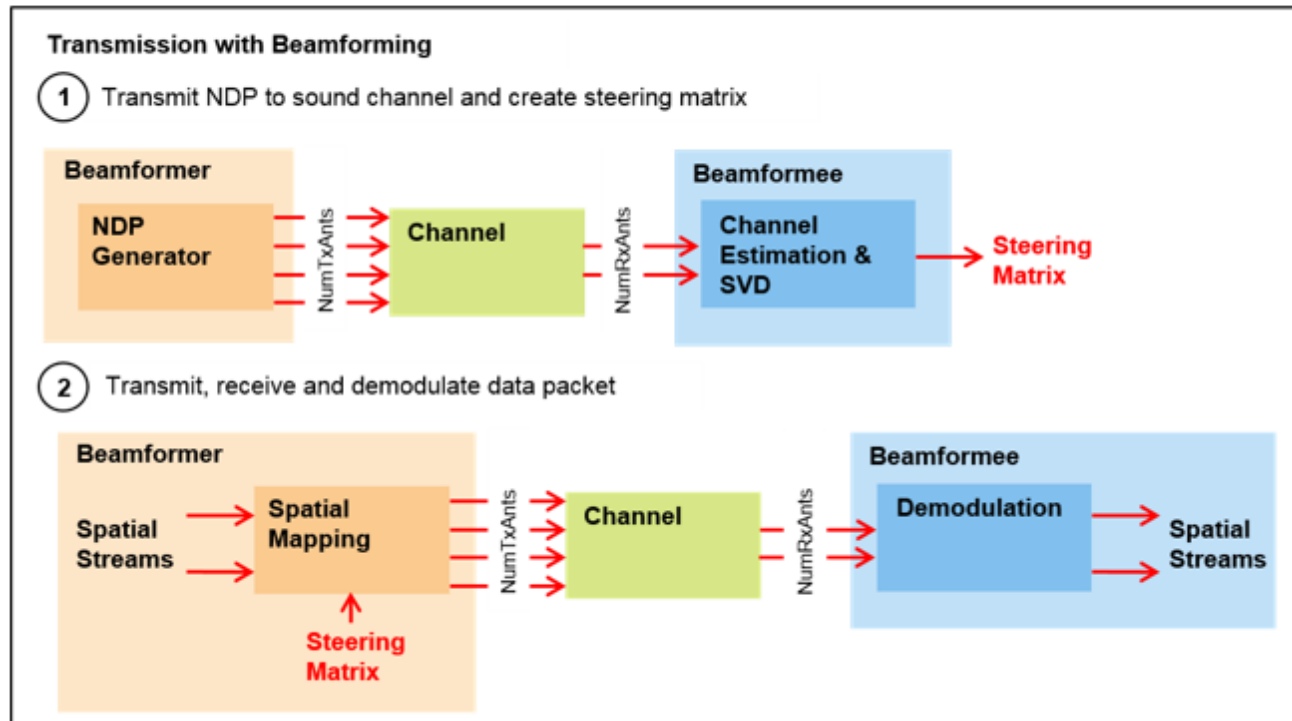
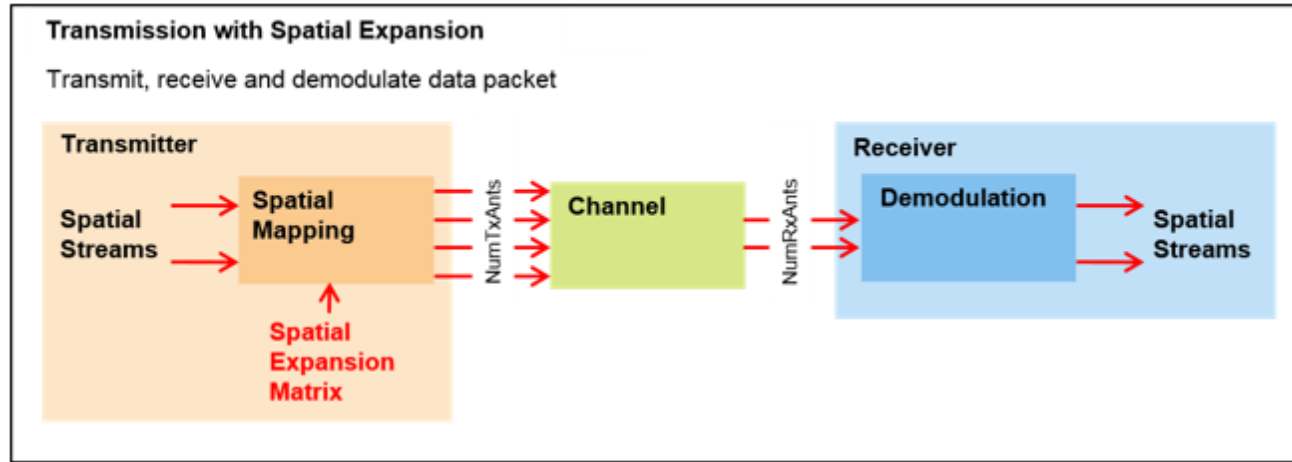

Spatial Expansion vs. Beamforming

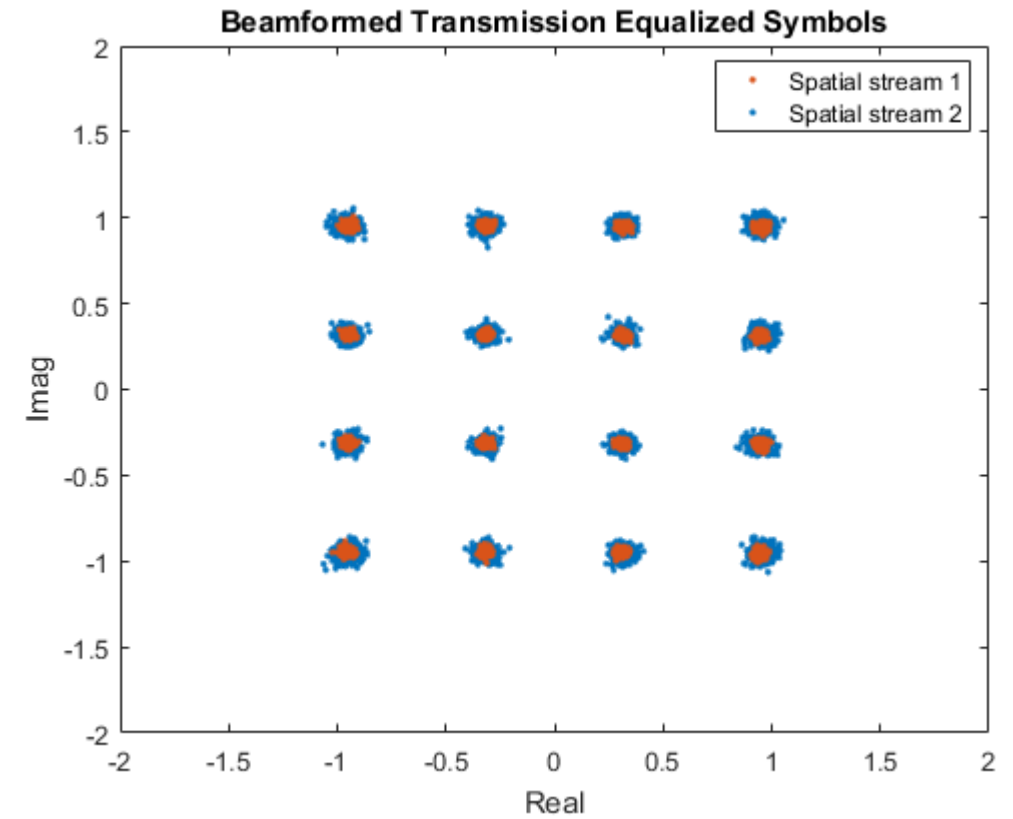
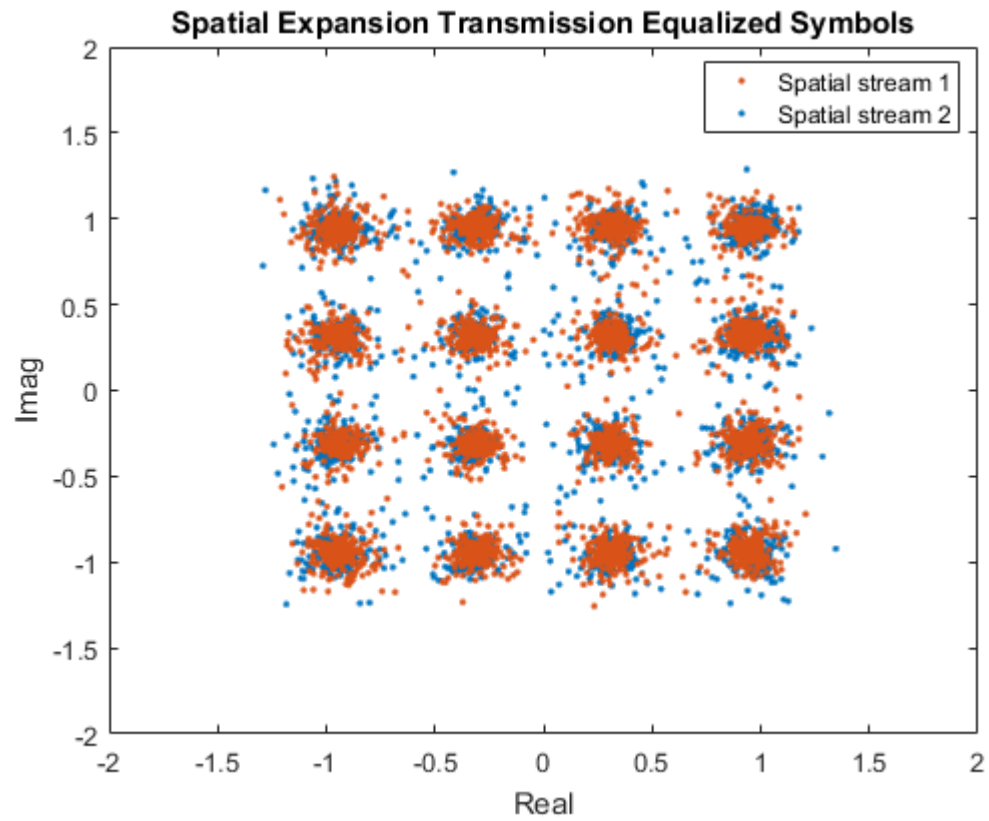

Example: Interference Cancellation with LTE Signals

- Interference cancellation with LTE signals
- Cell edge scenario
- **Phased Array System Toolbox**
- **LTE System Toolbox**

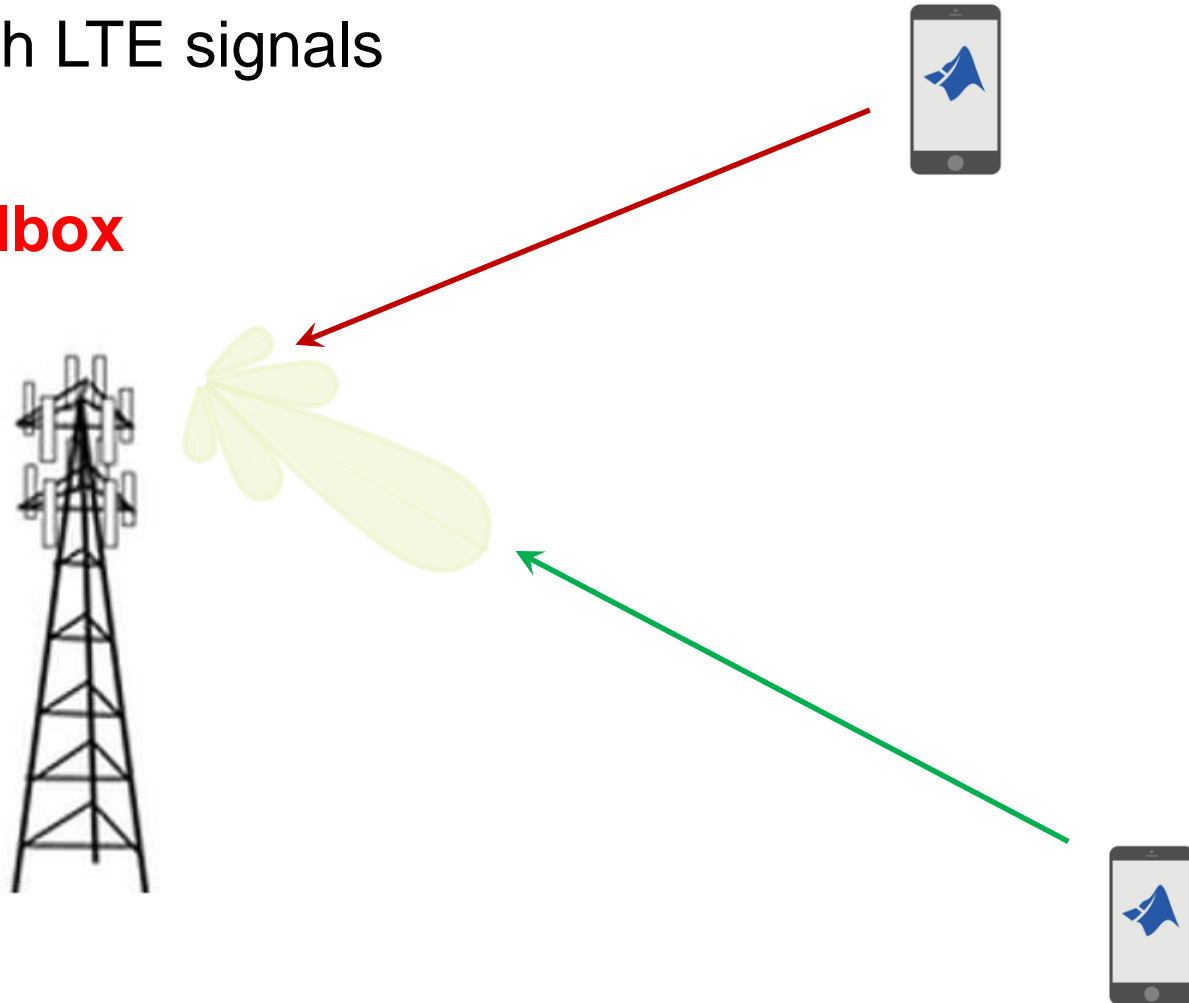

LTE Interference Cancellation using Antenna Arrays

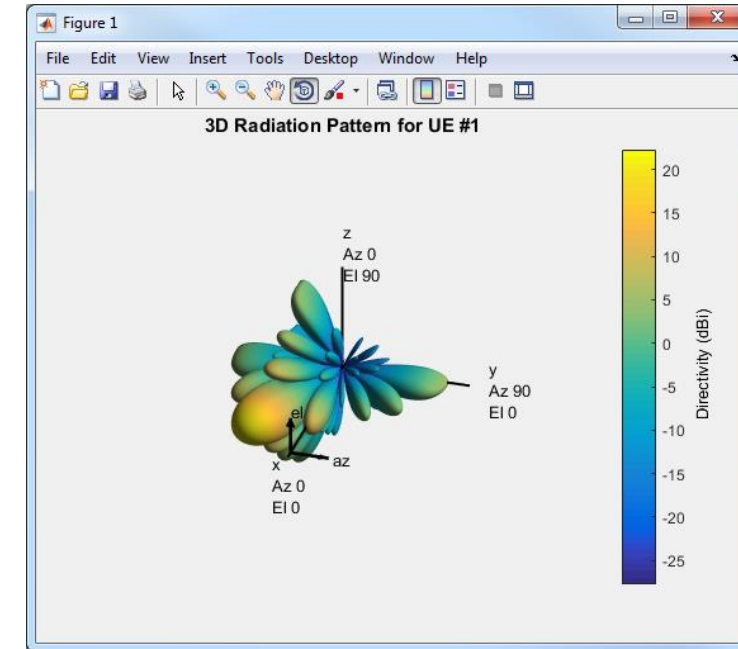
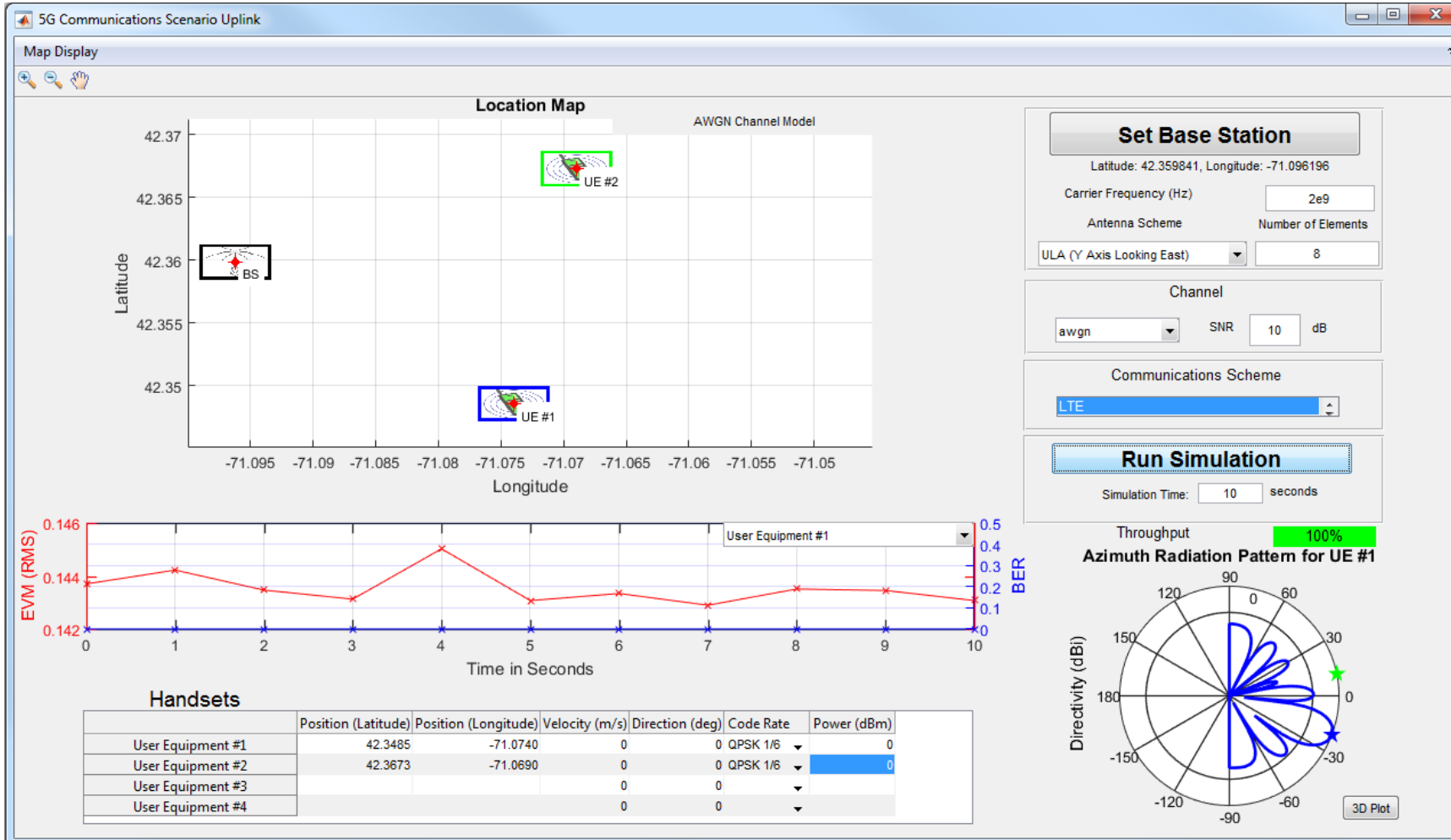

4G to 5G Evolution

A 5G vision

Use cases

- Ultra mobile wideband
- Enhanced capacity
- Massive device connectivity
- Robust IoT

Requirements

- Ultra broadband
- Ultra narrowband
- Reduced latency
- Massive device connectivity
- Energy saving
- Cost reduction
- Tight interworking with LTE

Solutions

- Existing & new bands (below and above 6GHz)
- Carrier aggregation
- New waveforms (OFDM based?)
- Massive MIMO
- Flexible duplex
- Shorter TTIs, small latency
- Advanced receivers
- Flexible cells (micro, pico, femto)

How Can *Today's* MATLAB Help?



Antenna-to-bits simulation
Design and verify wireless systems

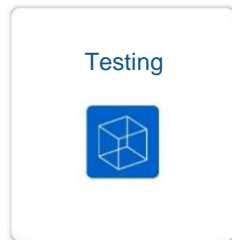

Over-the-air testing
Validate models with SDR and RF instruments

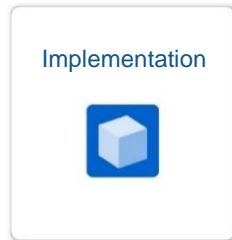

Prototyping and Implementation
Deploy algorithms onto target system



Design continuity from simulation to prototyping to implementation

Some 5G Challenges and our Solutions

- **LTE and WLAN Evolution**
 - LTE and WLAN System Toolbox
- **New Modulation Schemes: FBMC, UFMC, etc...**
 - MATLAB & Communication System Toolbox
- **Beamforming and Massive MIMO**
 - Phased Array System Toolbox & Antenna Toolbox
- **New Frequency Bands: mmWave**
 - SimRF & Antenna Toolbox
- **Advanced Receivers:**
 - DSP System Toolbox & Communication System Toolbox
- **Hardware Prototyping: Fast FPGA Prototyping**
 - HDL Coder: Automatic VHDL Generation
 - SDR Support Packages

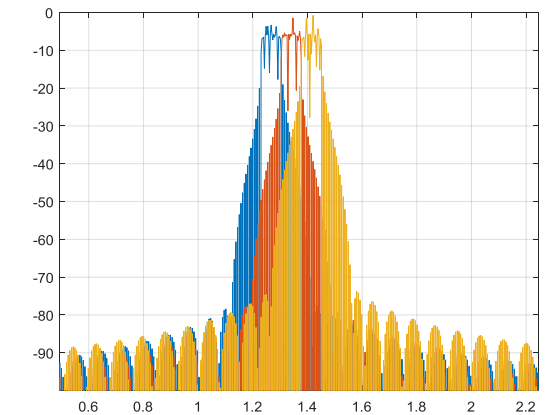
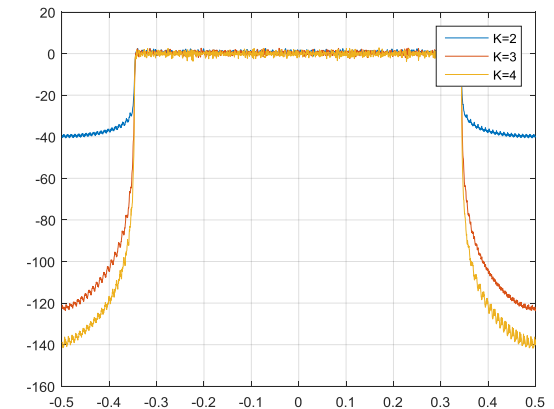

5G Waveforms: New Modulation Schemes

- 5G systems require:
 - spectral efficiency
 - relaxed synchronization requirements
- Majority of candidates: Multi-carrier, Non-Orthogonal waveforms
- Some candidates:
 - OFDM
 - FBMC: Filter-Bank Multi-Carrier
 - UFMC: Universal Filtered Multi-Carrier
 - GFDM: Generalized Frequency Division Multiplexing

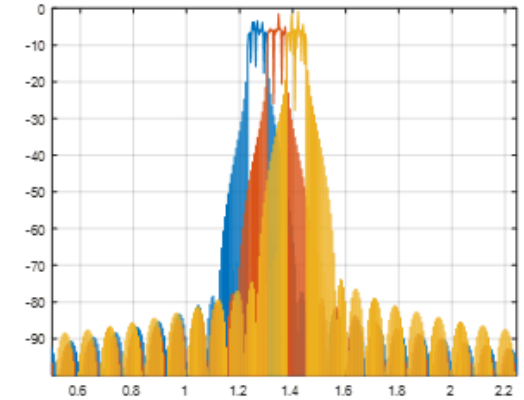
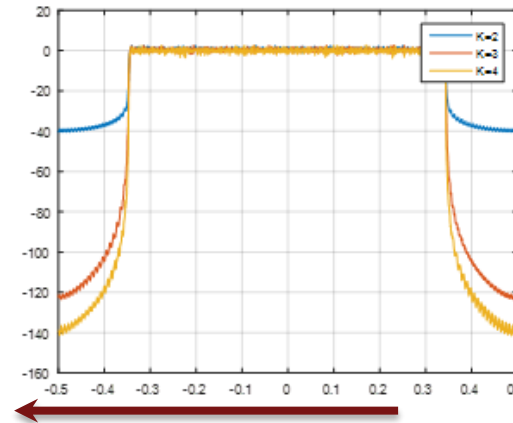

Filter-Bank Multi-carrier (FBMC)

- Introduce per-subcarrier filtering to reduce the side-lobes
- Couple of implementation options:
 - Frequency spreading (extended iFFT/FFT)
 - Poly-phase network (more efficient, commonly employed)

Disadvantages:

- Non-orthogonal in complex plane, overlapped symbols
- A more complicated receiver structure, esp. for MIMO

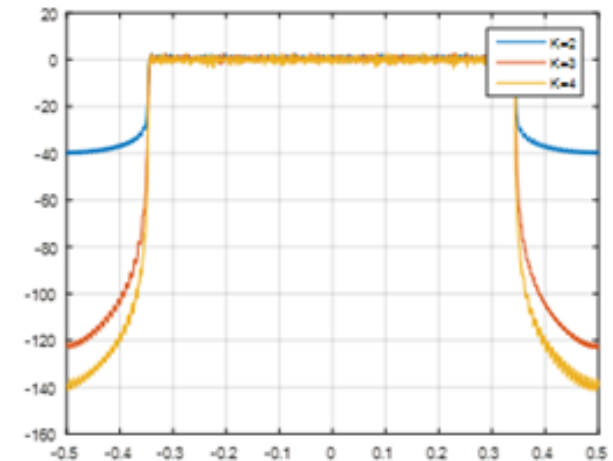

Universal Filtered Multi-carrier (UFMC)

- Filtering applied per sub-bands (not per sub-carrier as in FBMC)
 - Filtering parameterized by side-lobe attenuation
 - Reduced filter length (compared to FBMC)
 - Good for short bursts, suited for uplink with multiple users
- Orthogonal in the complex plane
 - use QAM symbols, reapply MIMO schemes
- Receiver complexity
 - Similar to OFDM, use per subcarrier equalization

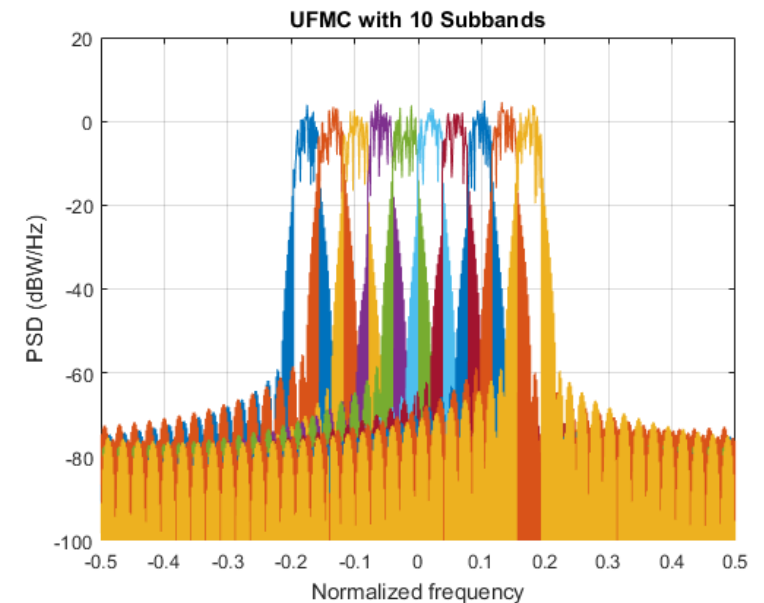

Evaluating the Performance of UFMC

LTE System
Toolbox

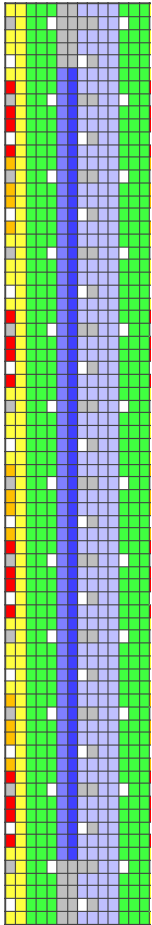

LTE resource grid

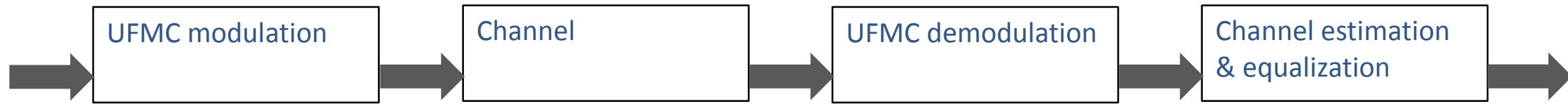

- Need reference symbols
- Need a realistic signal structure

Uplink UFMC

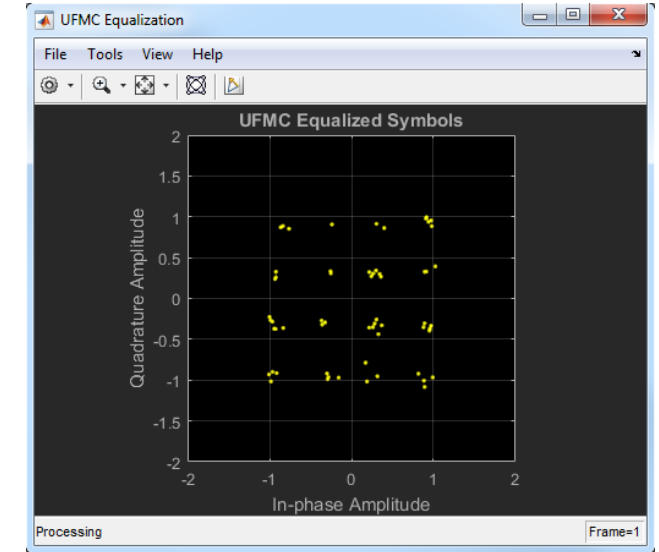
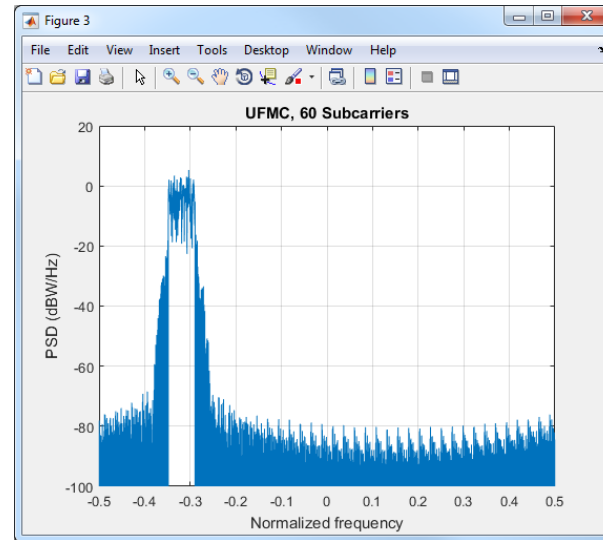
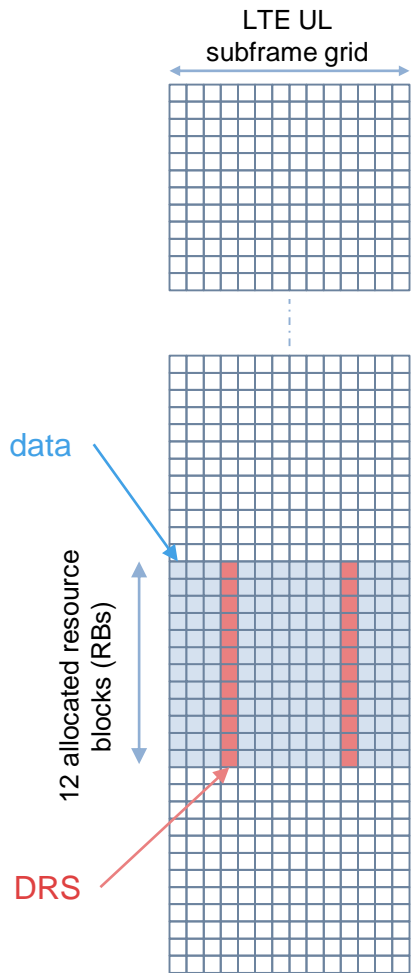

Interference Reduction using Massive MIMO

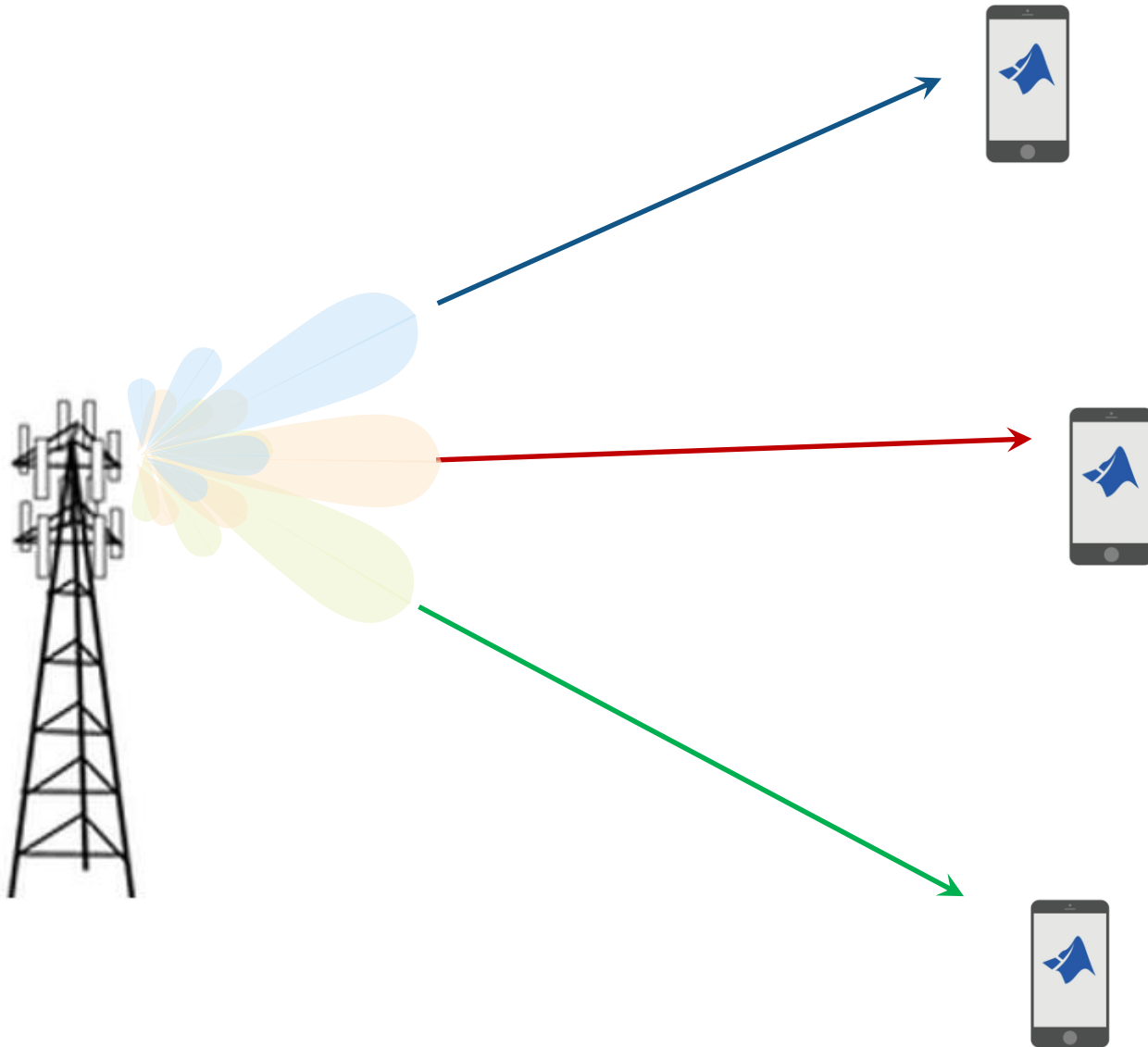

- Separate users in space
- Measure interference
- LTE System Toolbox
- Phased Array System Toolbox

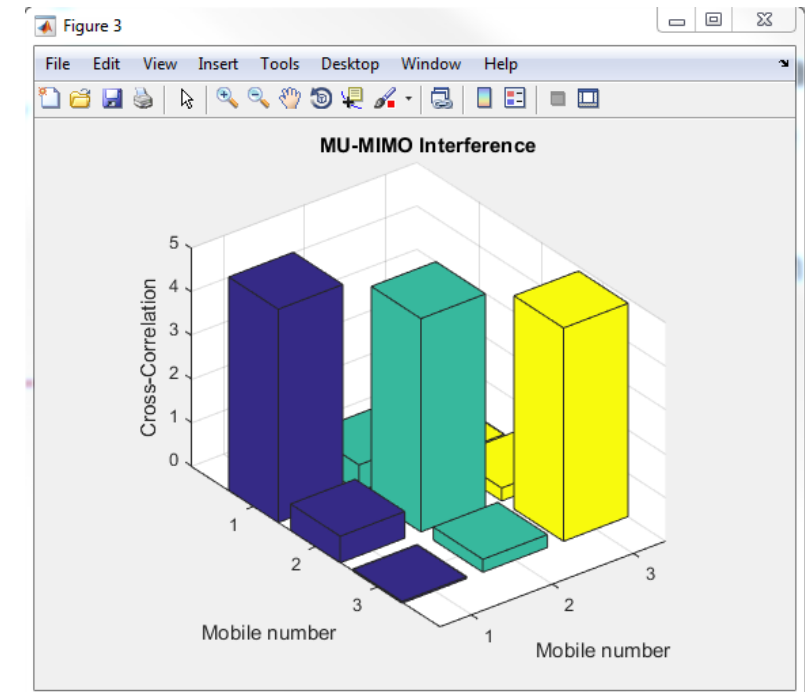

System Setup

